

# TOMEI Camshaft Spec Card

The Engine Specialist

PART NAME **PONCAM**

ENGINE **VR38DETT**

PART NUMBER SET **TA301A-NS01A** IN **TA301C-NS01A** EX **TA301E-NS01A**

GRIND	IN	258° /10.30mm	SOLID
	EX	266° /10.30mm	SOLID

LIFT	IN	@CAM 10.30mm	@VALVE 10.00mm
	EX	@CAM 10.30mm	@VALVE 9.97mm

LOBE CENTER(°)	IN	124.0
	EX	115.0

BASE CIRCLE	IN	Φ35.4
	EX	Φ35.4

VALVE CLEARANCE WHEN COLD	IN	0.30mm
	EX	0.33mm

ROCKER ARM RATIO*	-
-------------------	---

\* ALL LIFTS ARE BASED ON ZERO LASH AND THORETICAL ROCKER ARM RATIOS

CAM TIMING		OPENS(°)		CLOSES(°)		Actual Duration @ Opening(°)
Actual Duration Valve Lift	IN	BTDC	4.0	ABDC	74.0	258.0
	EX	BBDC	67.0	ATDC	19.0	266.0

Values shown are, from start to the end of actual duration. (Excluding the ramp values)

CAM TIMING		OPENS(°)		CLOSES(°)		TOTAL DURATION(°)
at 1mm Valve Lift	IN	ATDC	12.0	ABDC	58.0	226.0
	EX	BBDC	51.0	ATDC	3.0	234.0

Values are of actual duration from start to end of 1mm value points. (Excluding the ramp values)

CAM TIMING		OPENS(°)		CLOSES(°)		TOTAL DURATION(°)
at 0.05" Valve Lift	IN	ATDC	14.0	ABDC	56.0	222.0
	EX	BBDC	49.0	ATDC	1.0	230.0

Values are of actual duration from start to end of 0.05" value points. (Excluding the ramp values)

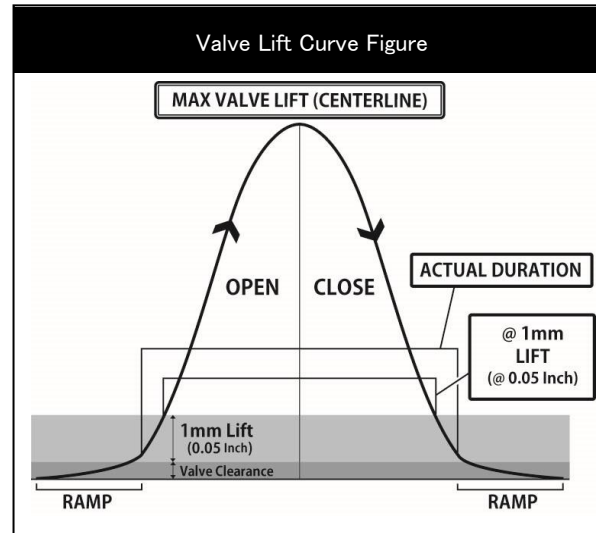

REQUIRED VALVE SPRING SPEC			
NORMAL HEIGHT	STD or IN	45.1mm	EX 45.1mm
SET LENGTH		36.6mm	33.7mm
LIFT LENGTH		25.6mm	22.5mm
COMPRESSED HEIGHT		21.7mm	21.7mm
SET LOAD		22.0kgf±6%	32.0kgf±6%
LIFT LOAD		60.0kgf±6%	70.0kgf±6%
PART NUMBER	TA304A-NS01A		

REQUIRED PARTS	
PRODUCT NAME	PART NUMBER

Dowel pin position when first cam lobe is pointing upwards.

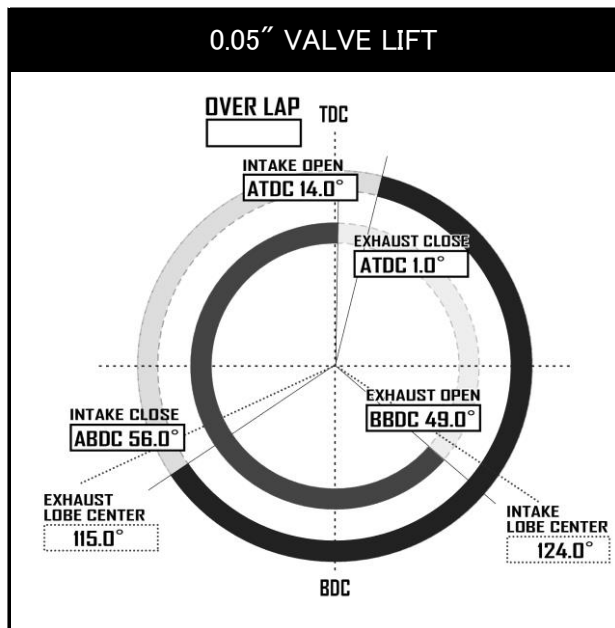
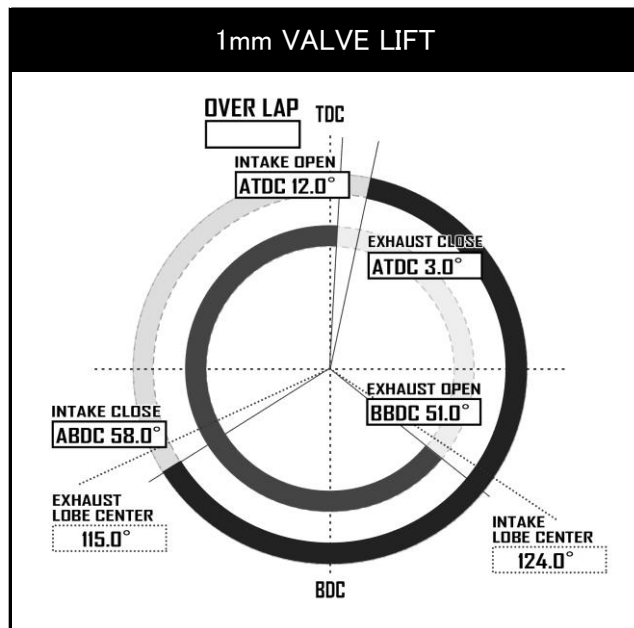
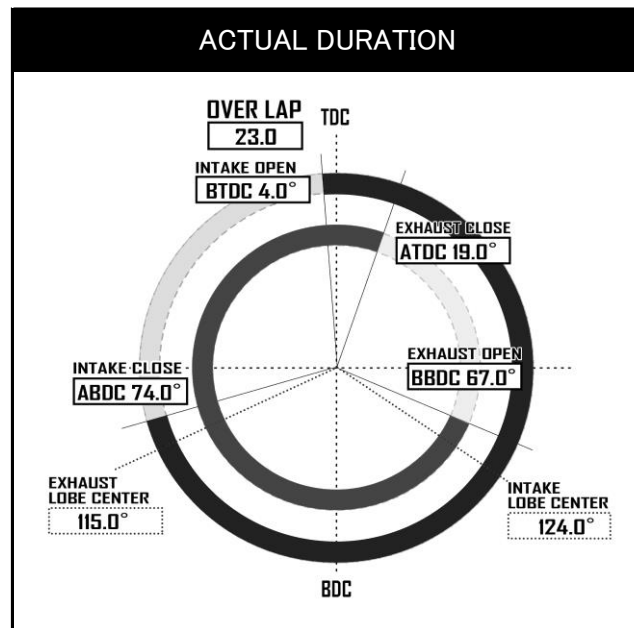
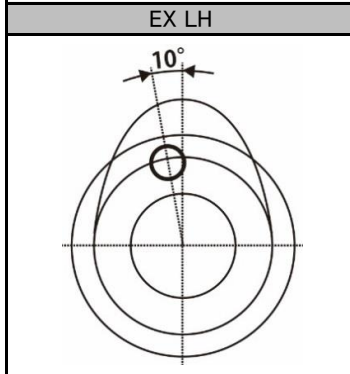
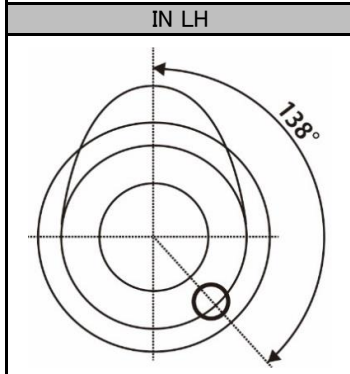
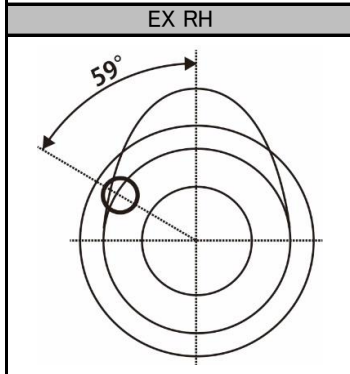
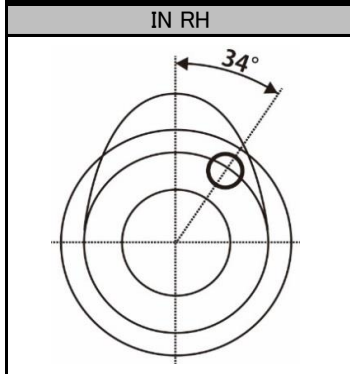

# TOMEI Camshaft Spec Card

The Engine Specialist

品名	PONCAM		適合	VR38DETT	
品番	SET	TA301A-NS01A	IN	TA301C-NS01A	EX TA301E-NS01A

スペック	IN	258° / 10.30mm	SOLID	リフト	IN	@CAM 10.30mm	@VALVE 10.00mm	初期設定 中心角(°)	IN	124.0	ベース円	IN	Φ35.4
	EX	266° / 10.30mm	SOLID		EX	@CAM 10.30mm	@VALVE 9.97mm		EX	115.0		EX	Φ35.4

冷間時	IN	0.30mm	ロッカーアームレシオ*	* すべてのリフト値はラッシュアジャスターが動作していない時、およびロッカーアームレシオから計算した理論値です。										
バルブクリアランス	EX	0.33mm	-											

カムタイミング		OPENS(°)		CLOSES(°)		Actual Duration @ Opening(°)
有効作用角	IN	BTDC	4.0	ABDC	74.0	258.0
バルブリフト	EX	BBDC	67.0	ATDC	19.0	266.0

ランプ部を除いた有効作用角の始点と終点の数値

カムタイミング		OPENS(°)		CLOSES(°)		TOTAL DURATION(°)
1mm バルブリフト	IN	ATDC	12.0	ABDC	58.0	226.0
	EX	BBDC	51.0	ATDC	3.0	234.0

ランプ部を含めたバルブの開き始めと閉じ終わりから1mmの点での数値

カムタイミング		OPENS(°)		CLOSES(°)		TOTAL DURATION(°)
0.05" バルブリフト	IN	ATDC	14.0	ABDC	56.0	222.0
	EX	BBDC	49.0	ATDC	1.0	230.0

ランプ部を含めたバルブの開き始めと閉じ終わりから0.05インチの点での数値

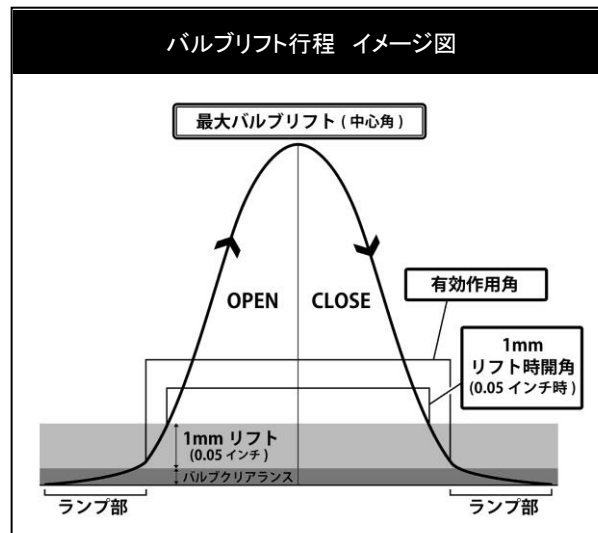

推奨バルブスプリング		STD or IN	EX
自由長		45.1mm	45.1mm
セット長		36.6mm	33.7mm
リフト長		25.6mm	22.5mm
密着長		21.7mm	21.7mm
セット荷重		22.0kgf±6%	32.0kgf±6%
リフト荷重		60.0kgf±6%	70.0kgf±6%
品番		TA304A-NS01A	

必要部品		品番
製品名		

