

TOMEI Camshaft Spec Card

The Engine Specialist

PART NAME **PONCAM** ENGINE **SR20DET S14/S15**

PART NUMBER SET **TA301B-NS08B** IN **TA301D-NS08B** EX **TA301F-NS08A**

GRIND	IN	258° /11.50mm	LASH
	EX	258° /11.50mm	LASH

LIFT	IN	@CAM 7.41mm	@VALVE 11.50mm
	EX	@CAM 7.41mm	@VALVE 11.50mm

LOBE CENTER(°)	IN	120.0
	EX	115.0

BASE CIRCLE	IN	Φ32.0
	EX	Φ32.0

VALVE CLEARANCE WHEN COLD	IN	-
	EX	-

ROCKER ARM RATIO*	1.55 : 1
-------------------	----------

* ALL LIFTS ARE BASED ON ZERO LASH AND THORETICAL ROCKER ARM RATIOS

CAM TIMING		OPENS(°)	CLOSES(°)		Actual Duration @ Opening(°)
Actual Duration Valve Lift	IN	BTDC 8.0	ABDC 70.0		258.0
	EX	BBDC 63.0	ATDC 15.0		258.0

Values shown are, from start to the end of actual duration. (Excluding the ramp values)

CAM TIMING		OPENS(°)	CLOSES(°)		TOTAL DURATION(°)
at 1mm Valve Lift	IN	BTDC -12.0	ABDC 50.0		218.0
	EX	BBDC 43.0	ATDC -5.0		218.0

Values are of actual duration from start to end of 1mm value points. (Excluding the ramp values)

CAM TIMING		OPENS(°)	CLOSES(°)		TOTAL DURATION(°)
at 0.05" Valve Lift	IN	BTDC -14.0	ABDC 47.0		213.0
	EX	BBDC 41.0	ATDC -8.0		213.0

Values are of actual duration from start to end of 0.05" value points. (Excluding the ramp values)

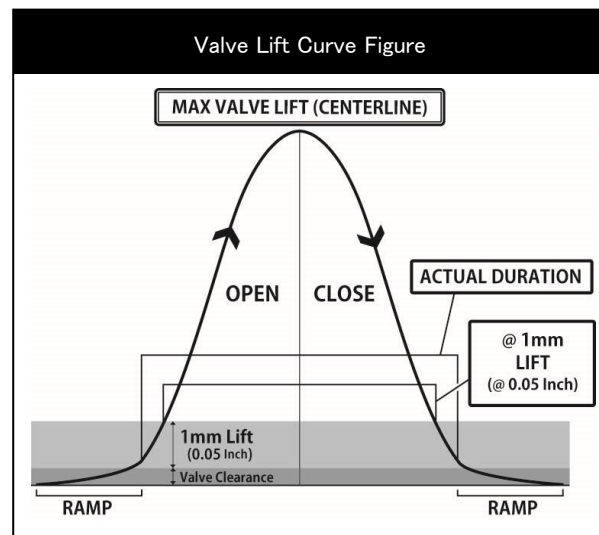

REQUIRED VALVE SPRING SPEC	
NORMAL HEIGHT	STD or 48.0mm
SET LENGTH	40.0mm
LIFT LENGTH	27.5mm
COMPRESSED HEIGHT	26.5mm
SET LOAD	25.6kgf±7%
LIFT LOAD	81.6kgf±7%
PART NUMBER	173004

REQUIRED PARTS	
PRODUCT NAME	PART NUMBER

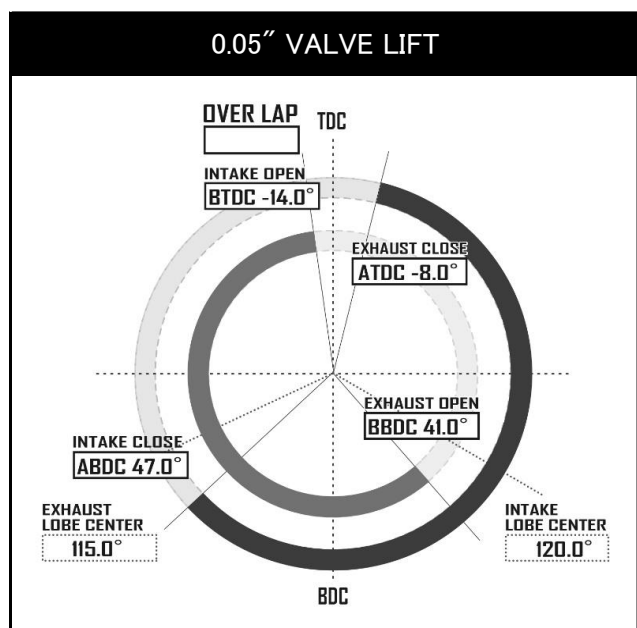
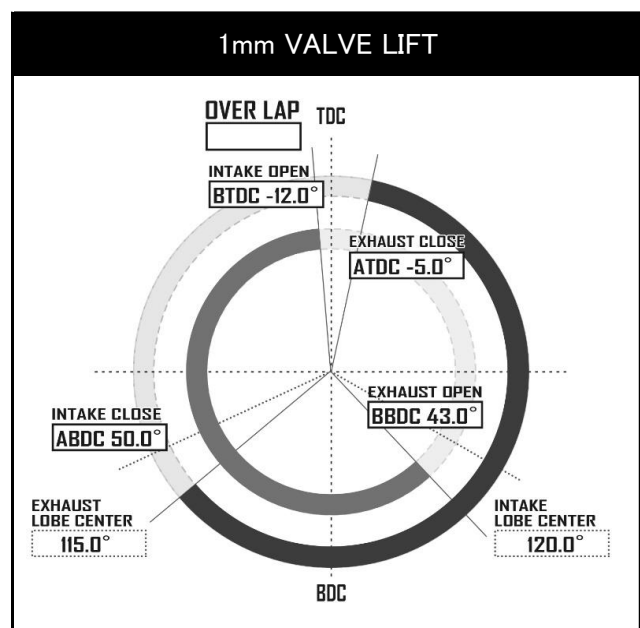
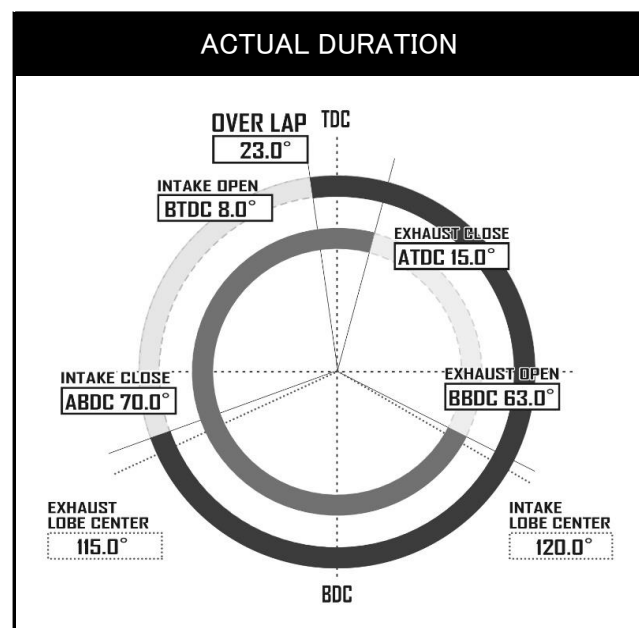

Dowel pin position when first cam lobe is pointing upwards.

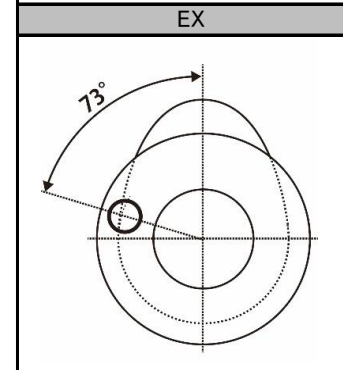
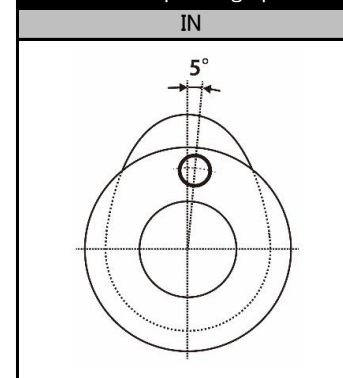

TOMEI Camshaft Spec Card

The Engine Specialist

品名 **PONCAM** 適合 **SR20DET S14/S15**

品番 **SET TA301B-NS08B IN TA301D-NS08B EX TA301F-NS08A**

スペック	IN	258° /11.50mm	LASH
	EX	258° /11.50mm	LASH

リフト	IN	@CAM 7.41mm	@VALVE 11.50mm
	EX	@CAM 7.41mm	@VALVE 11.50mm

初期設定 中心角(°)	IN	120.0
	EX	115.0

ベース円	IN	Φ32.0
	EX	Φ32.0

冷間時	IN	-
バルブクリアランス	EX	-

ロッカーアームレシオ*	1.55 : 1
-------------	----------

* すべてのリフト値はラッシュアジャスターが動作していない時、およびロッカーアームレシオから計算した理論値です。

カムタイミング		OPENS(°)		CLOSES(°)		Actual Duration @ Opening(°)
有効作用角 バルブリフト	IN	BTDC	8.0	ABDC	70.0	258.0
	EX	BBDC	63.0	ATDC	15.0	258.0

ランプ部を除いた有効作用角の始点と終点の数値

カムタイミング		OPENS(°)		CLOSES(°)		TOTAL DURATION(°)
1mm バルブリフト	IN	BTDC	-12.0	ABDC	50.0	218.0
	EX	BBDC	43.0	ATDC	-5.0	218.0

ランプ部を含めたバルブの開き始めと閉じ終わりから1mmの点での数値

カムタイミング		OPENS(°)		CLOSES(°)		TOTAL DURATION(°)
0.05" バルブリフト	IN	BTDC	-14.0	ABDC	47.0	213.0
	EX	BBDC	41.0	ATDC	-8.0	213.0

ランプ部を含めたバルブの開き始めと閉じ終わりから0.05インチの点での数値

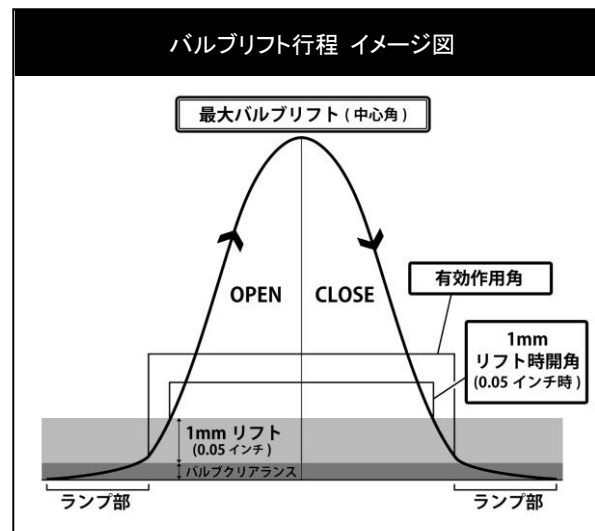

推奨バルブスプリング	
自由長	STD or 48.0mm
セット長	40.0mm
リフト長	27.5mm
密着長	26.5mm
セット荷重	25.6kgf±7%
リフト荷重	81.6kgf±7%
品番	173004

必要部品	
製品名	品番

